

FILTER CAGES AND SLEEVES INSTALLATION MANUAL

DOUBLE G JUNCTION

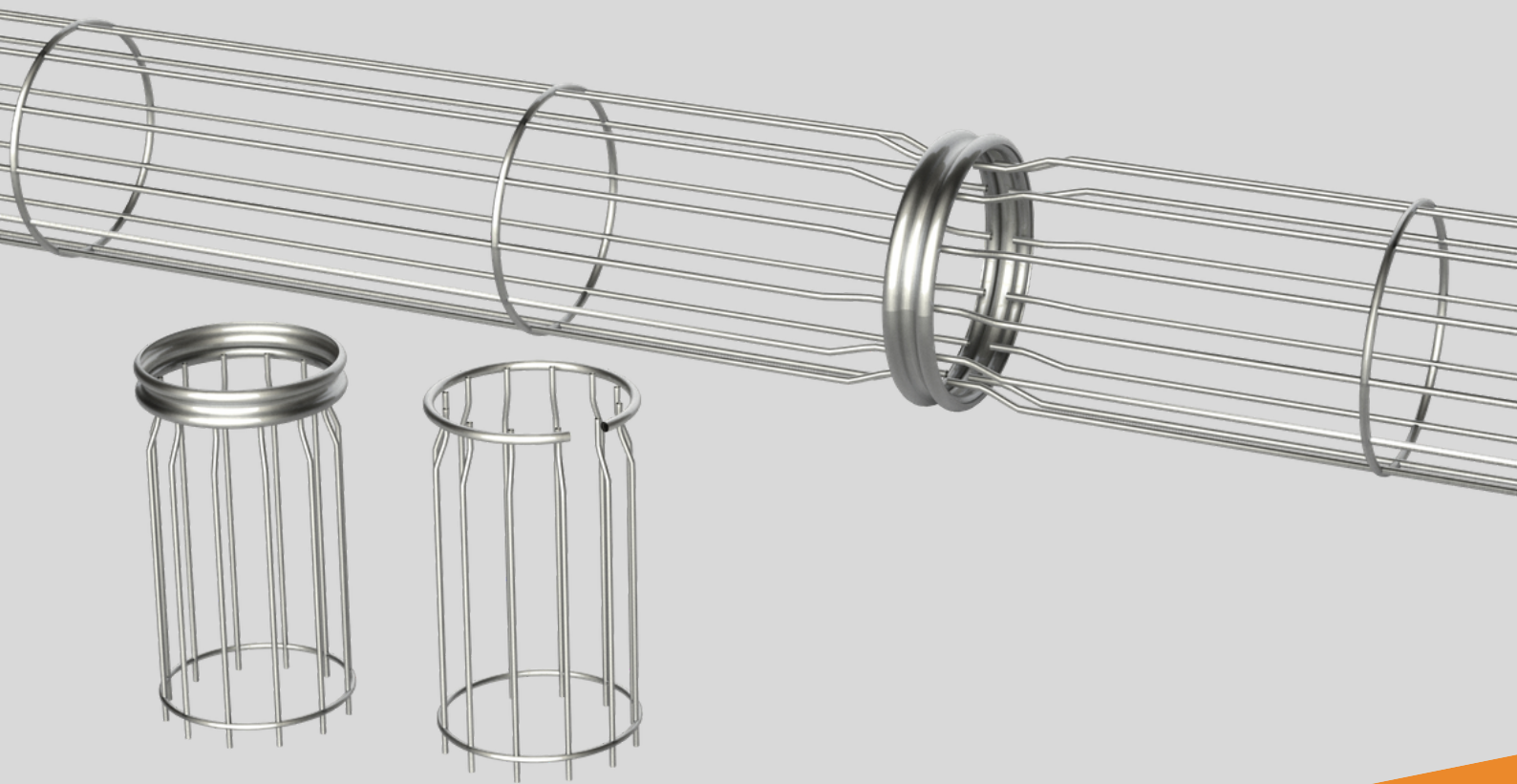

FILTER CAGES AND SLEEVES INSTALLATION MANUAL

Index

■	1: INTRODUCTION	02
■	2: RECOMMENDED ACCESSORIES AND SAFETY DEVICES	02
■	3: MAXIMIZE THE DURATION OF THE FILTER SLEEVES	03
■	4: ADVANTAGES OF USING CLEAN CAGES	03
■	5: IMPORTANT INSTRUCTIONS	03
■	6: WHAT A CAGE IS MADE OF	04
■	7: DIFFERENT TYPES OF COLLARS	04
■	8: HOW TO IDENTIFY THE CONTENTS OF THE CRATES	05
■	9: HANDLING AND STORAGE MANUAL	05
■	10: INSTALLATION PROCEDURE	06

FILTER CAGES AND SLEEVES INSTALLATION MANUAL

Introduction:

The manual is mainly intended for installers of cages for filter sleeves, for the industrial air filtration. It is intended to suggest how to properly install the product and reduce those behaviors that, in addition to compromising correct installation, can seriously damage the product.

Recommended accessories and safety devices:

The correct use of all the equipment necessary for the installation of the filter baskets and sleeves is fundamental to reduce maintenance, labor and overall operating costs, as well as avoiding problems during installation. The correct use of the procedures described in the PPE is essential

Gloves



Safety goggles



Protective helmet



Pliers

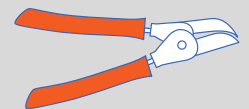

High visibility jacket

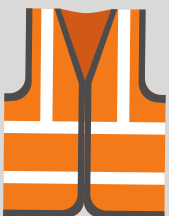

Metal bars



Safety shoes



Wooden bars

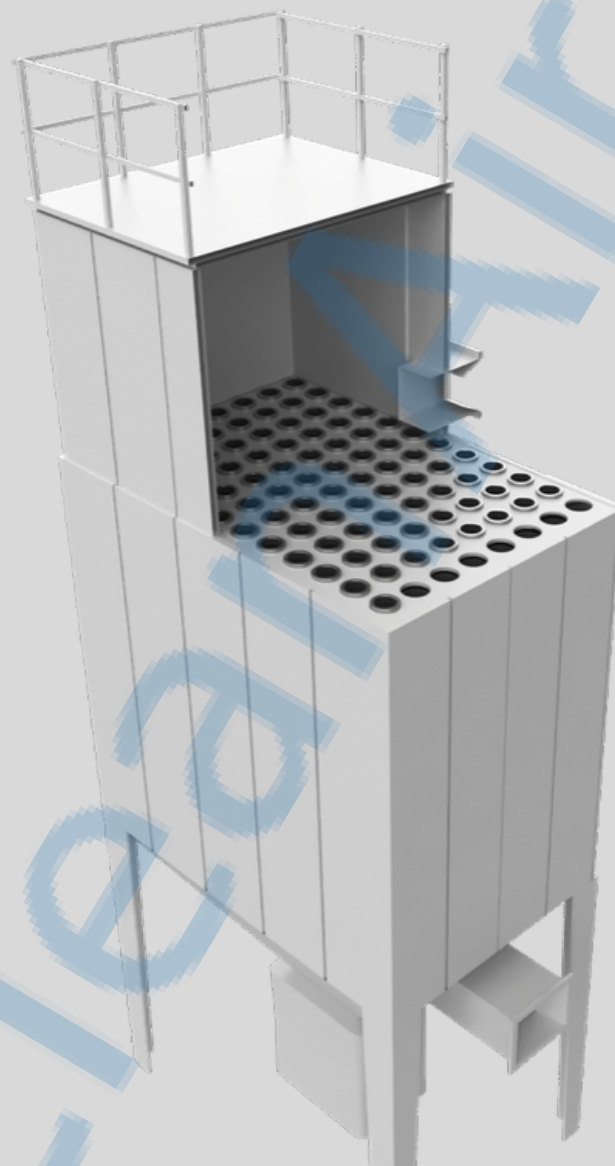
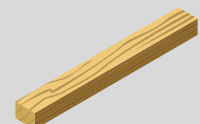

FILTER CAGES AND SLEEVES INSTALLATION MANUAL

■ Maximize the duration of the filter sleeves

Properly designed cages serve as critical baghouse components for optimum bag performance, durability and longer bag life.

Our cages are constructed of the following materials:

- Stainless steel type S235JR
- Pre-galvanized Stainless steel
- Stainless steel type AISI 304 L (Wr. 1.4301)
- Stainless steel type AISI 316 L (Wr. 1.4404)

■ Advantages in using CleanAir cages

All the longitudinal bars or wires that compose the cage, are welded on inner rings and inside the I bottoms part and collars.

- Top collars and bottoms parts are molded with rounded edges to reduce abrasion.
- The stringer wires in our cages are consistently spaced so that the cage diameter is the same from top to bottom, promoting proper bag-to-cage fit.
- The top collar is fixed with the wires welded inside, helping to avoid premature bag failure, while the longitudinal wires are welded inside the bottom part, or welded to a terminal ring to which the bottom can be grafted.
- The longitudinal wires are welded to the rings through dedicated and controlled welding processes, to avoid the presence of burrs or sharp parts.

CleanAir has obtained the ISO 3834 part 2 certification (extended quality requirements), the standard dedicated to welding for the fusion of metallic materials, which implements the most restrictive conditions from the qualitative point of view.

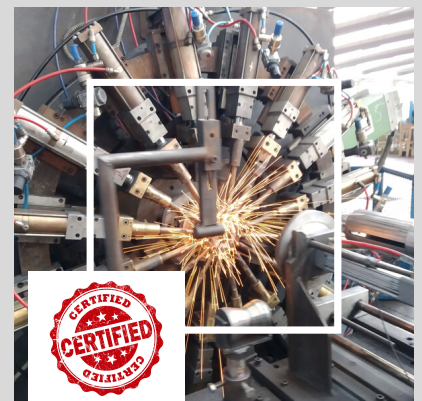

■ Important instructions

It is suggested to pay attention to the instructions below:

1. Locate the symbol printed on the case
2. Follow the instructions provided in the PPE
3. Use the handling and storage manual supplied separately or by scanning the QR code

FILTER CAGES AND SLEEVES INSTALLATION MANUAL

What a cage is made of

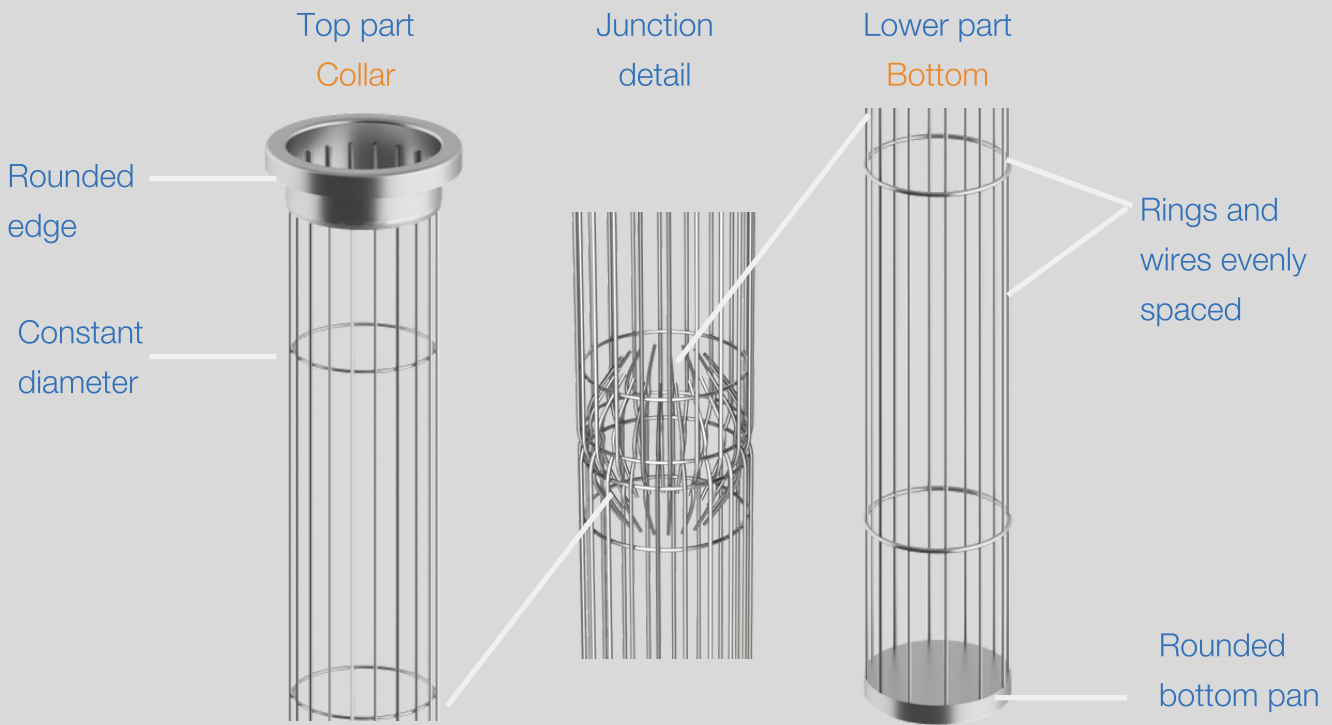

Different types of collars

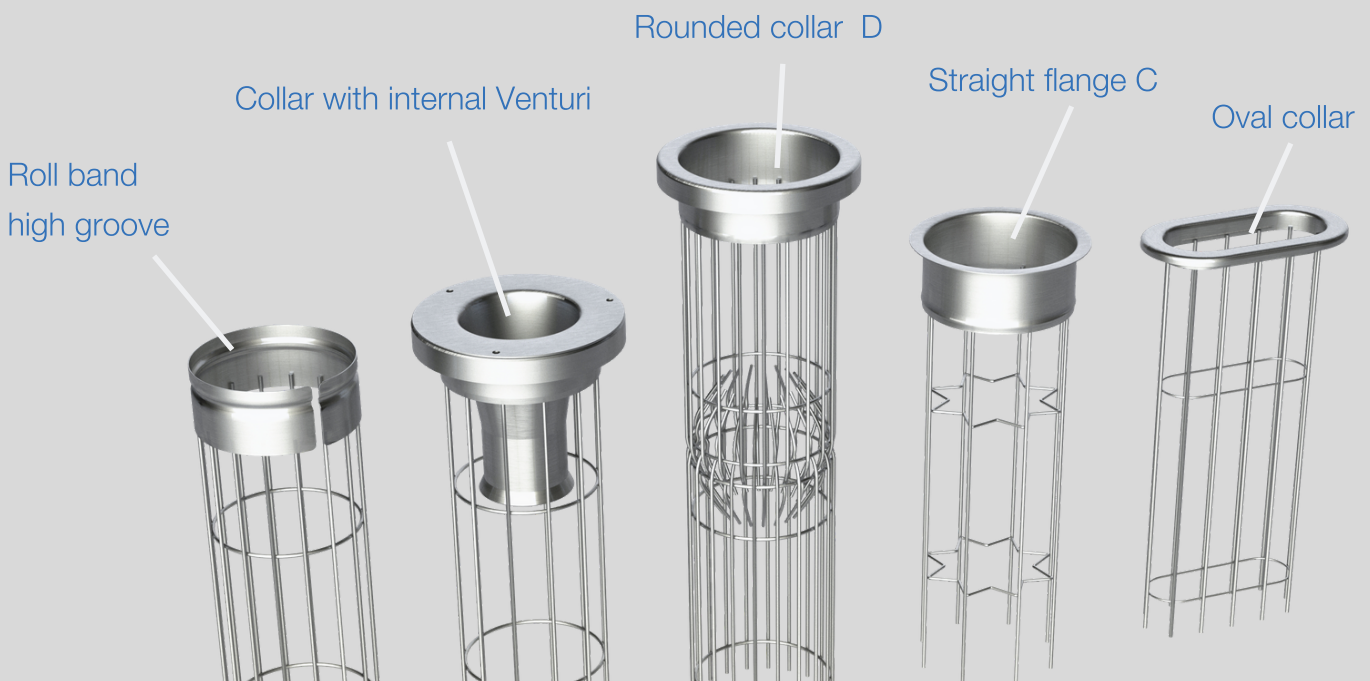

FILTER CAGES AND SLEEVES INSTALLATION MANUAL

How to check the contents of the crates

Identify the symbol printed on the case to check the part of the basket

Top part



Internal part



Bottom part



Handling and storage manual

Use the handling and storage manual provided separately
or scan the QR code

Handling manual
PDF

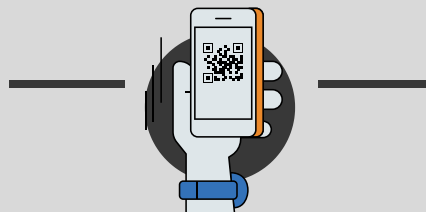

Handling manual
VIDEO



INSTALLATION PROCEDURE

1° PHASE

Insert the first part (bottom) of the cage into the tube sheet hole and inside the already installed filter bag.

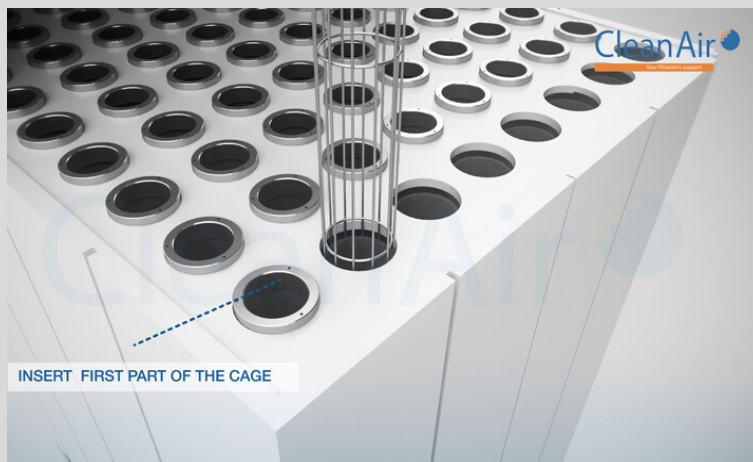

2° PHASE

Insert a metal/wood plank in the cage before the penultimate ring in order to block the cage at the base of the tube sheet.

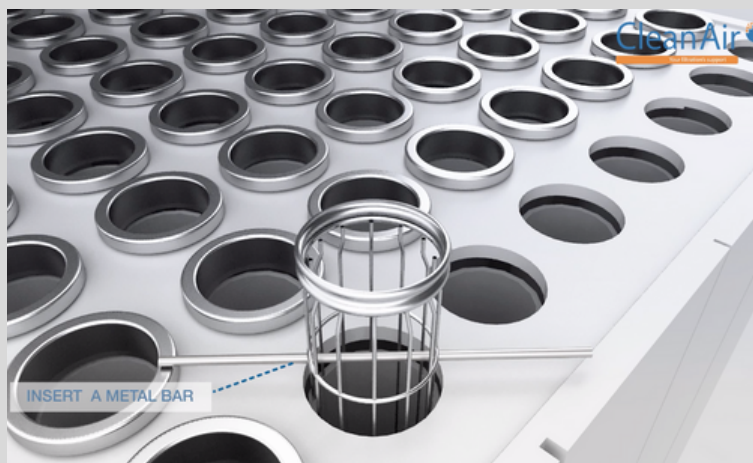

3° PHASE

Take then the second part (intermediate or top) of the cage; place the locking ring of the bottom part near the junction.

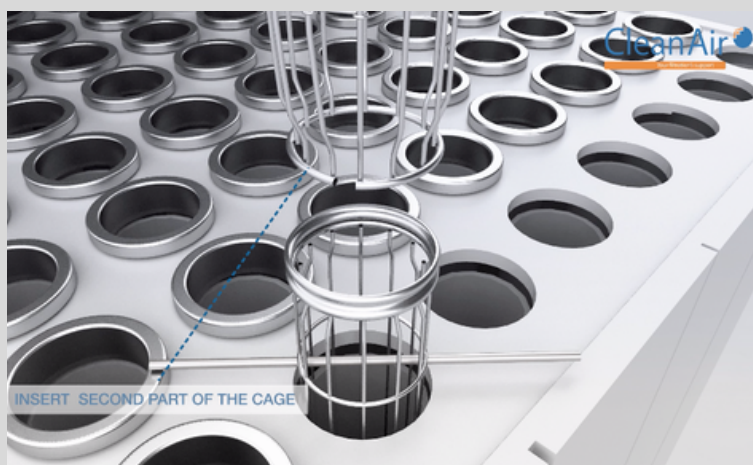

INSTALLATION PROCEDURE

4° PHASE

Use a pincer to tighten the locking ring and insert it into the junction. Then release (the pincer) to let the ring expand into the metal gorge of the cage's bottom part. Lower the locking hook of the junction ring.

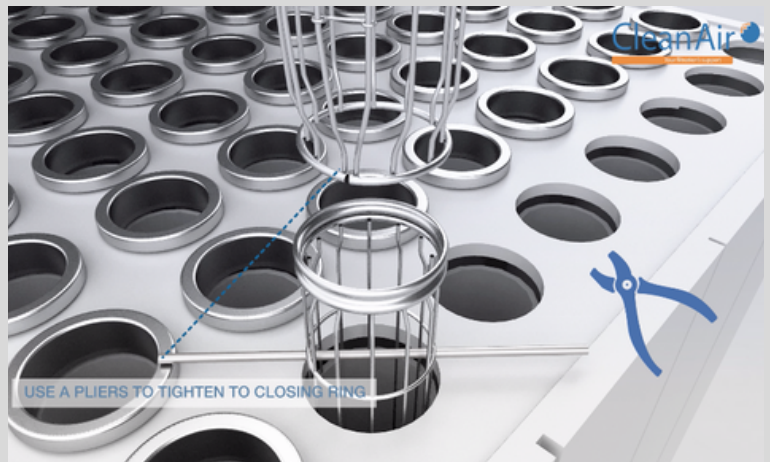

5° PHASE

Having inserted the second part of the cage into the bottom part, ensure that the two parts have been properly hooked and lift the whole cage up in order to test the mechanical seal.



6° PHASE

Keep the cage lifted so that to allow the metal/wood plank removal. Make sure that the plank lays away from the installation area, together with the other devices.

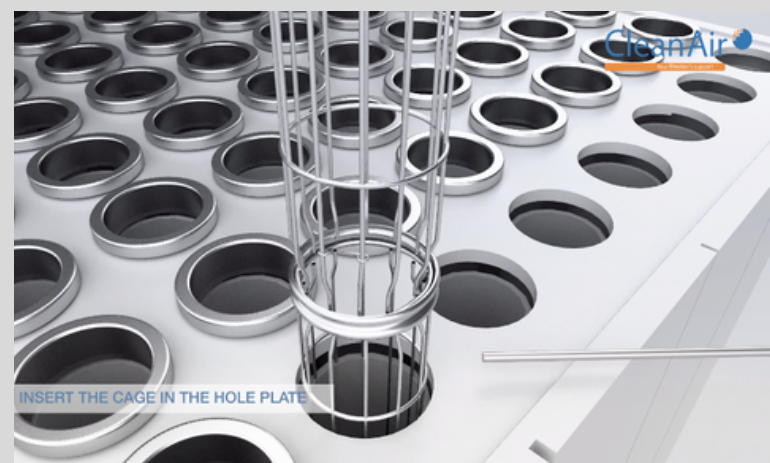

INSTALLATION PROCEDURE

7° PHASE

Having removed the supporting plank, lower the whole cage into the tube sheet hole and the filter bag till when it reaches the limit switch; lay the upper collar on the tube sheet and finish to fit the filter bag up to the collar.

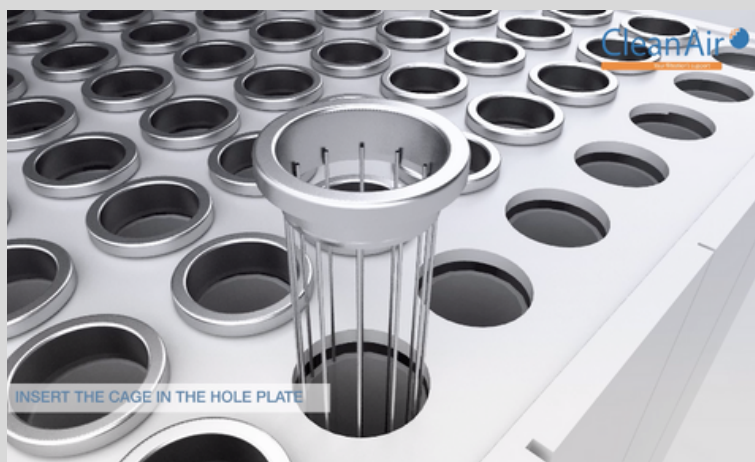

SUGGESTION!!

Make sure that filter cage properly fit in the bag. Ensure that all the devices and packing materials have been removed from the installation area and eventually clean up the zone before activating the plant.



CleanAir 



Clean Air Europe S.r.l.
Via Roma 84 - 23892 Bulciago (LC)
P.iva 03011000134 Tel. +39 031 4153551 | Fax +39 031 4153553
info@cleanairworld.it | www.cleanairworld.it @cleanairworld

